

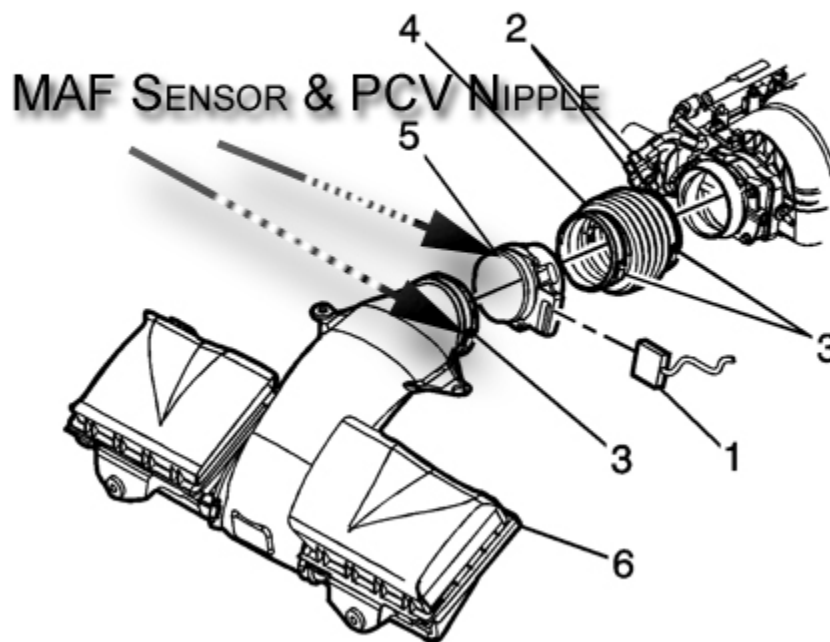

## Halltech C6 Venom Installation

- 1) Uninstall the stock C6 AIS and set the MAF sensor aside for use with the Venom AIS (Air Induction System)

### UNINSTALL THE STOCK C6 AIS



- 2) Set the MAF sensor, plastic side down, on a hard surface. Heat the bottom of the bridge and install it over the metal end of the MAF. Align the airfoil inside the MAF perpendicular.



3) This is a completed view of the Venom without the filter:



4) Check the filter carefully for any loose rubber that might have dislodged during shipping, and then set it down in the bottom of the shroud area. Install the bridge assembly to the throttle body, tighten the hose clamp, and insert into the filter. **DO NOT OVERTIGHTEN!**

